

# Development and Applications of Line Following Robot Based Health Care Management System

Deepak Punetha, Neeraj Kumar, Vartika Mehta

**Abstract**— This paper report describes the techniques for analyzing, designing, controlling and improving the health care management system. A line following robot carrying medicine has been designed for providing the medicine to the patient whenever they need it. A Line follower robot is an electronic system that can detect and follow the line drawn on the floor. Generally, the line is specified a predefined path that can be either visible like a black line on a white surface with a high contrasted color. Light dependent resistor sensor has been attached with the robot whose resistance varies with light intensity. When the LDR receives maximum amount of light then its resistance goes to its minimum value, ideally zero and when no light falling on the LDR then its resistance goes to its maximum value, ideally infinite. A switch with IR sensor has been fitted near the patient, which connection has been made by the robot too. If the patient presses the switch then a flag bit set in the microcontroller, from which line following robot follows the line and got reached near the patient and provide the medicine to the patient with the help of dc motor. A proximity sensor also has been attached with the robot so that robot can detect any obstacle on their ways and can alarm. The ability to get someone around the clock is the best thing that this system can do. This technology focused on the delivery of safe, timely, efficient, effective, patient-centered and equitable health care.

**Index Terms**— Health care; LDR; Medicine; IR Proximity sensor; Microcontroller; Comparator; DC motor; Motor driver; Alarm circuit.

## I. INTRODUCTION

A health care system is defined as the organization of the people, resources and the institute to provide the health care services to the person or population. The goal of health care management system is to provide good health. For maintaining the health different organization, institutes, charities, religious and the government are planning around the world. This health care system also includes the hospitals, health care institution or clinics either these are operated by government, private for profit organization and

also private not for profit organizations. All around the world, many patients suffers because of to pay medical practitioners taken by the health care system. This health care system includes the health care staff personnel that are doctors, nurse, security guards, sweepers and many more.

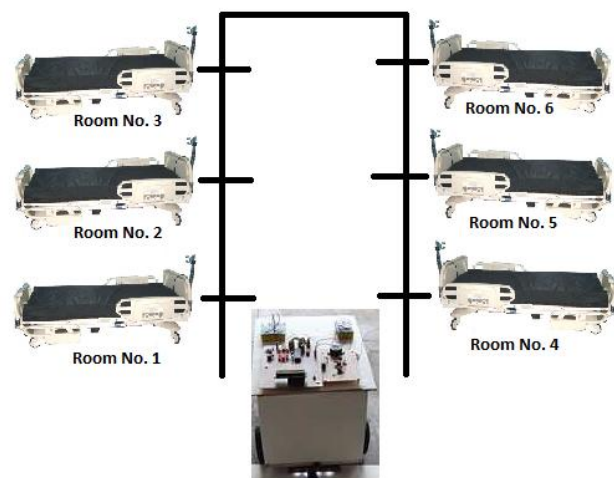

Figure 1. Line following robot with health care rooms.

The fee for the medical practitioners depends on the service, medicine, capitation and the salary of the personnel. And also it is very difficult to continuous monitoring of the patients. That line following robot based health care management system can be very efficient to continuous monitoring to the patients, whenever they need any help or medicine. For continuous monitoring of the patients, health care system needs many personnel. From which the fee for the medical practitioner will hike. That robot based health care management system can reduce the fee for the patients so that they can easily pay that amount of money.

## II. MOTIVATION

Around the world thousands of patients died because of not properly monitored them. Research shows that the number of patients died because of few numbers of trained medical staff [10]. Shortage of nurses is 'killing thousands a year': Patients in overstretched hospitals developing fatal complications which could have been cured [8]. A lot of hospitals have stopped recruiting nurses and medical personnel since 2005 and 2006. From the past two years there is an increasing trend of recruiting more doctors than the nurses. If sufficient number of nurses based on the patient numbers visiting a hospital are recruited than the number of deaths can be estimated decreased by 10 % [8].

Manuscript received Jul, 2013.

Deepak Punetha, Department of Electronics and Communication Engineering, Chitkara University, Pinjore-Barotiwala Highway (NH-21A), Himachal Pradesh-174103, India.

Neeraj Kumar, Department of Electronics and Communication Engineering, Chitkara University, Pinjore-Barotiwala Highway (NH-21A), Himachal Pradesh-174103, India.

Vartika Mehta, Department of Electronics and Communication Engineering, Graphic Era University, Dehradun, Uttarakhand-248002, India.

Contrasting conditions					
Countries	Expenditure on health as % of GDP		Hospital beds	Nurses	Physicians
	Government	Private			
Germany	7.8	2.7	82	108	35
UK	7.2	1.5	34	103	21
USA	7.3	7.9	31	98	27
Japan	6.7	1.6	138	41	21
Russia	3.1	1.7	97	85	43
Brazil	3.7	4.7	24	65	17
South Africa	3.3	4.9	28	41	8
Thailand	3.0	1.1	22	15	3
China	2.0	2.3	41	14	14
Vietnam	2.8	4.4	29	10	12
India	1.4	2.8	9	13	6
Global median	5.0	3.3	24	28	12

Figure 2. WORLD HEALTH STATISTICS 2008 [14].

The critical patients in a hospital and health care environment need a continuous monitoring with the help of sophisticated equipments which only trained and skilled nurses can operate efficiently and effectively [3]. So the medical personnel become of paramount importance to deliver a quality health care to its patients. This detection and alert system may help the human by saving the life of accident victims.

### III. PROBLEM DEFINITION

The government bodies try to implement various strategies to increase the potency of the health care system in the countries. But they generally fail due to various reasons such as enormity of the task at hand, huge budget, expensive equipment and non availability of skilled staff. Further this issue reaches a point where prevention takes a back step and most of the energy and resources are spent on treating the ailments. So, in order to reduce cost and provide better health care 'Prevention' should be the new mantra for this situation. But the question arises 'how to prevent it?'

### IV. RELATED WORK

In robotics there are many system invented which has different applications in different fields. Robotics is very popular field for research and manufacturing. A two wheels balancing robot has developed by Nor Maniha Abdul Ghani et.al, which has the line following capability and for balancing it, they used infra-red distance sensor to solve the problem in inclination [7], [6]. Pakdaman M. et.al has design a small line following robot which used IR sensors to detect the line drawn on floor [9]. That system has designed for the robot competition. Colak I. et.al has design a line following robot to use in the shopping malls for entertainment. That system used 4.8 cm wide black line to carry maximum load of 400 kg. They also used a manual control with the help of remote controller [2]. A physical robot with 50 individual controls is generated by Gomi T. et.al from which the ability and gait to lift the body can be improved. That robot can move its legs in forward motion and tested in different conditions [13]. Roman Osorio C. et.al designed an intelligent line following robot, which can modify the performance of the movement with the help of different type of magnetic sensors. That robot was based on the V2X sensor which is a type of digital compass [12]. Priyank Patil has

developed an AVR line following robot which can detect the line drawn on the floor with the help of sensor array. When its sensor is passing through the line drawn on the way then it reads 0 and vice versa [11]. This system is used an array of 8 IR sensors and several LEDs. M. Zafri Baharuddin et.al designed a mobile robot which can be used as the navigation purpose [5]. An intelligent robot system is designed by Bajestani S. E. M. which can give corrective feedback in different colors of light [1]. They used a comparator circuit to improve the sensitivity of the system. That comparator compares the voltage with the predetermined amounts from which a robot can move in accurate real time.

### V. SYSTEM OVERVIEW

This smart and intelligent Line following robot based health care management system has divides in several parts- sensing, comparator, motor driver and actuators. This device is LDR and IR proximity sensors for sensing purposes. LDR is used for which a robot can follow the line drawn on the floor [4]. IR proximity sensor used for stop the robot when any object came to it path. Comparator circuit is used for set a threshold value from which it can set logic when it detects the light. Motor driver is use for controlling the motor. And actuator is use for make the system dynamic.

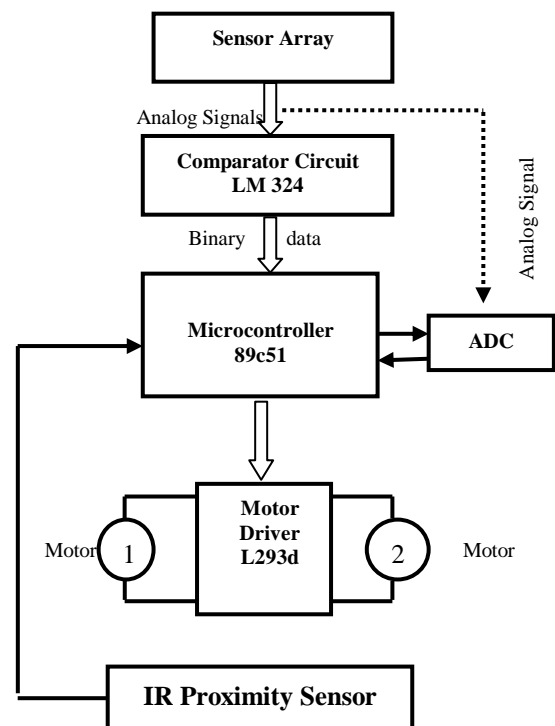

Figure 3. Block diagram of Line Following Robot based health care management system.

The system is connected with the microcontroller to make the system automatic. When it detect the light or any obstacle then the flag bit of microcontroller is set from which the dc motor can be controlled.

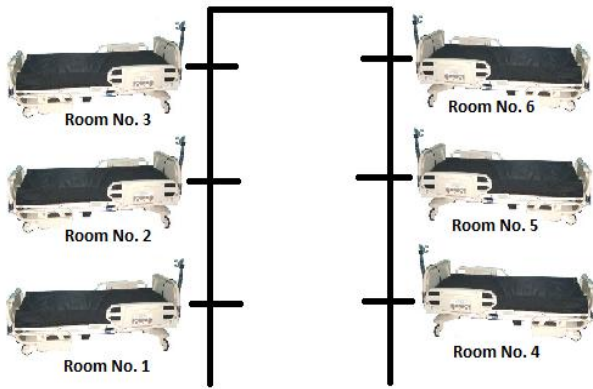

Figure 4. Patient rooms with line drawing on the floor.

A. Sensors

This system has used two type of sensors circuit. One is LDR based another is IR proximity sensor.

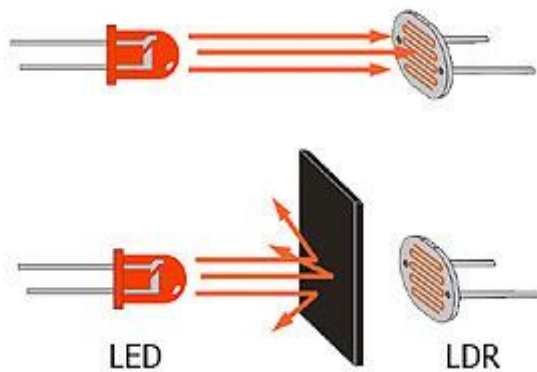

Figure 5. Light Dependent Resistor (LDR) Sensor.

LDR is a light dependent resistor which works by incident light on it. Its resistance varies according to change in the intensity of light. As the light falls on the LDR then it shows very high resistance ideally infinite and when there is not any light beam incident on it then it shows very less resistance ideally zero. That means if a voltage apply in the one terminal of the LDR then it gives zero voltage at another end if there is any light falls and vice versa.

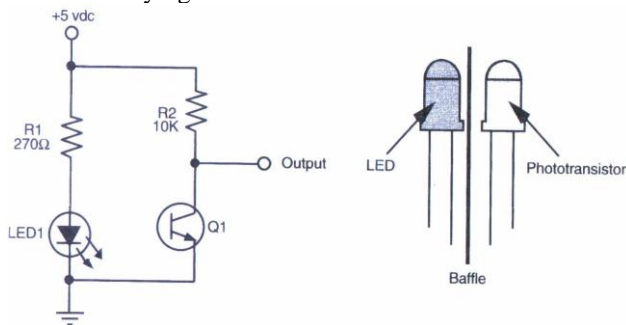

Figure 6. IR Proximity Sensor.

IR proximity sensor is the infrared sensor, which use for detect the obstacle. If any obstacle comes between the IR transmitter and the IR receiver then it gives the output. That output can be used as making device automatic and set the

flag bit of the microcontroller. It plays a vital role in the field of detecting any obstacle.

B. Comparator

Comparator is use to make the system sensitive as per the requirement. It usually compares the voltages between the inverting and non inverting terminals. A threshold voltage is set on the reference voltage in the operational amplifier in inverting or non inverting terminal. If another terminal voltage that is input voltage is greater than this threshold voltage then it gives the output. And if the input voltage is less then threshold voltage then it cannot gives any output. The sensitivity of the sensor can be varying by set a threshold voltage in the comparator circuit. By using this circuit a LDR sensor can be used for low beam of light and a IR proximity sensor for detect the obstacle from a large distance.

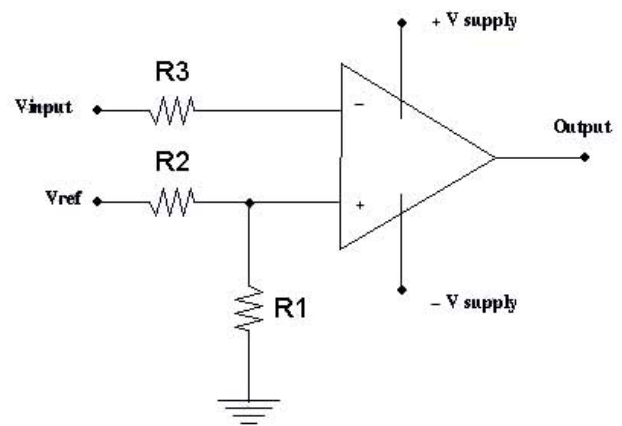

Figure 7. Comparator circuit.

C. Motor Driver

Motor driver act like the current amplifier. It is use for controlling the current in the motor. The motor drive provides high current as the dc motor need when it receives low current in the circuit. For drive the motors a high value of the current is needed. L293D IC can control the two dc motor simultaneously. It can rotate the motor in the forward and reverse direction. By using the motor driver a line following robot can be move in clockwise and in anticlockwise directions. It completely controls the movement of the dc motor that's why it has been called as motor driver.

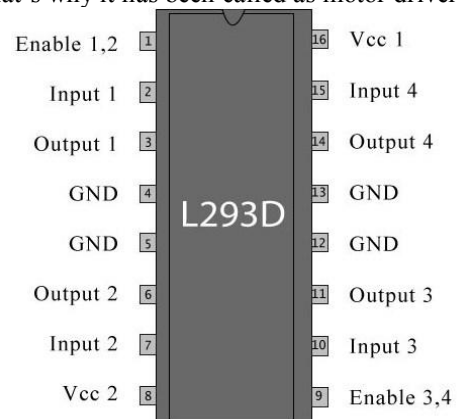

Figure 8. Motor driver IC.

#### D. Actuators (Motors and Wheels)

For the proper movement of the system two dc motors has been used in the circuit and a castor wheel is attached in the front side of that Line Following Robot Based Health Care Management System. Caster wheel enable the movement of the robot is easy in every direction. Two dc motors at the end side of the robot is controlled by the motor driver. For controlling the complete system a microcontroller is used, which set its flag bit as per the different situations. And this complete system need a small power supply of 9 V, which can be provided form a battery. That is why this system is cost effective and operates in very low power supply.

### VI. EXPERIMENT RESULTS

LDR is basically a variable resistor which changes with different intensity of light. With the help of comparator circuit it can give the output when it comes under the contact of that line drawn. By using motor driver it follows the line drawn on the floor. At the turn of the line drawn, LDR doesn't get any output. DC motor must be controlled by the motor driver for movement of the robot. For left movement the left side dc motor should be stop and the right side dc motor should be run in forward direction. Table I shows the different necessary conditions for movements of the motor.

TABLE I. DIRECTION MOVEMENT OF ROBOT

ROBOT MOVEMENT	LEFT MOTOR	RIGHT MOTOR
Straight	Straight	Straight
Left	Stop	Straight
Sharp Left	Reverse	Straight
Right	Straight	Stop
Sharpe Right	Straight	Reverse
Reverse	Reverse	Reverse

When the system detects any obstacle in its path then the dc motor stop rotating and a buzzer is activated with the help of microcontroller unit. Microcontroller can be use for controlling the health care system in every possible case. The interfacing of the microcontroller with the help of LCD is showing in the figure 9. And also a snapshot of the line following robot with the line drawn on the floor is showing in the figure 10.

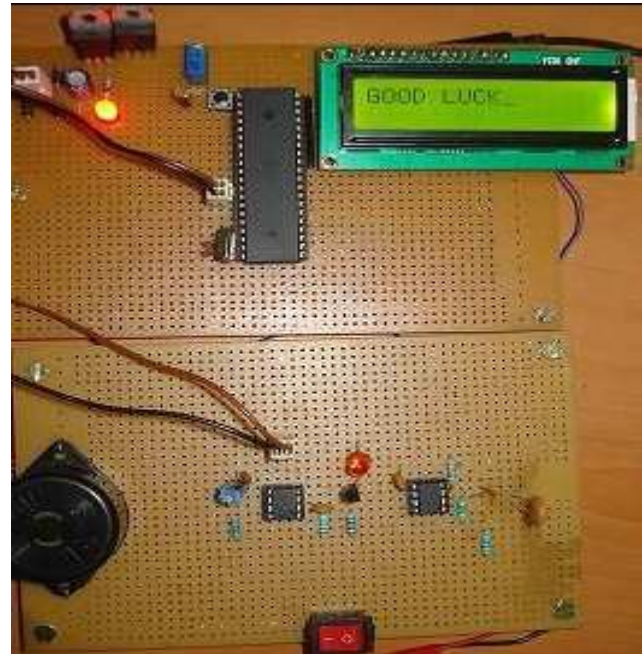

Figure 9. Microcontroller with LCD interfacing and alarm circuit



Figure 10. Snapshot of line following robot

### VII. FUTURE WORK

Line following robot based health care management system can play a vital role in the field of hospitality. Robotics is a grooming technology. By using robot in the government and private hospitals the cost for the cure can be reduced. It can be very beneficially for the patients. In India many people hesitate to admit in the hospital because of costly medical practitioner. Monitoring of every patient is very difficult for the nurses in the hospital. So a camera can be placed in the line following robot, from which the status for every patients can be handle from a single room. In the bed of the patient an accelerometer can be placed from which if a patient have a heart attack then that device can operate a alarm circuit. Line following robot's application over electronics engineering can't be underestimated. This line following robot can be use as carrying the load and many more applications. A GSM module can be placed with the line following robot so that if

any mishappening occurs then that system can make a call to the doctor. Robotics is very big field for the new innovation and research. By using the robot in real time applications, a health care system can be manage in an effectively way.

### VIII. CONCLUSION

The cost of health care majorly depends upon the expensive machinery, land and building and round the clock staff to maintain and use that machinery. In a country like India where the population is humongous and resources are scarce. It becomes really difficult to set up such a capital extensive project at each and every location with availability of skilled staff. So what this system provides is an alternate to the existing system by replacing skilled labor with robotic machinery, which in turn can handle more patients in less time with better accuracy and a lower per capita cost.

### REFERENCES

- [1] Bajestani, S.E.M., Vosoughinia, A., "Technical Report of Building a Line Follower Robot" International Conference on Electronics and Information Engineering (ICEIE 2010), vol 1,pp v1-1 v1-5,2010.
- [2] Colak, I., Yildirim, D., "Evolving a Line Following Robot to use in shopping centers for entertainment", Industrial Electronics, 2009. IECON '09. 35th Annual Conference of IEEE, pp.3803 - 3807,3-5 Nov. 2009.
- [3] Czosnyka M, Smielewski P, Kirkpatrick P, et al. Continuous monitoring of cerebrovascular pressure-reactivity in head injury. Acta Neurochir Suppl. 1998;71:74-7.
- [4] Datasheets of microcontroller AT89C51, LDR sensor, IR proximity sensor, Motor driver L293D, Comparator, 16\*2 LCD, Available: <http://www.alldatasheet.com>
- [5] M. Zafri Baharuddin, Izham Z. Abidin, S. Sulaiman Kaja Mohideen, Yap Keem Siah, Jeffrey Tan Too Chuan, "Analysis of Line Sensor Configuration for the Advanced Line Follower Robot", University Tenaga Nasional.
- [6] Miller Peter, "Building a Two Wheeled Balancing Robot", University of Southern Queensland, Faculty of Engineering and Surveying. Retrieved Nov 18, 2008.
- [7] Nor Maniha Abdul Ghani, Faradila Naim, Tan Piow Yon, "Two Wheels Balancing Robot with Line Following Capability," World Academy of Science, Engineering and Technology, pp-634-638, 2011.
- [8] Nursing shortage Statistic from around the world, Available: <http://www.dailymail.co.uk/health/article-2266158/Shortage-nurses-kill-ing-thousands-patients-year-Patients-likely-develop-complications-properly-monitored.html>
- [9] Pakdaman, M.; Sanaatiyan, M.M., "Design and Implementation of Line Follower Robot," Computer and Electrical Engineering, 2009. ICCEE '09. Second International Conference on , vol.2, no., pp.585-590, 28-30 Dec. 2009.
- [10] Patient Statistics from around the world, Available: <http://www.standard.co.uk/news/health/thousands-may-have-died-needle-sly-at-nhs-hospitals-shamed-in-report-8711159.html>
- [11] Priyank Patil, "AVR Line Following Robot," Department of Information Technology K. J. Somaiya College of Engineering Mumbai, India. Retrieved Mar 5, 2010.
- [12] Román Osorio, "Intelligent Line Follower Mini-Robot System", International Journal of Computers, Communications & Control Vol. I, No. 2 ,pp. 73-83 ,2006.
- [13] T. Gomi, K. Ide, "Evolution of gaits of a legged robot", IEEE International Conference on Fuzzy Systems 06/1998; DOI:10.1109/FUZZY.1998.687476 ISBN: 0-7803-4863-X In proceeding of: Fuzzy Systems Proceedings, 1998.
- [14] World Health Statistics presents, "Global Health Observatory (GHO)", the most recent health statistics for WHO's 193 Member States, 2008..



Mr. Deepak Punetha is presently working as Assistant Professor in Electronics and Communication Engineering Department at Chitkara University, Himachal Pradesh, India. He has more than 3 years of teaching experience. His area of interest is Electronics Product Design and Technology, Digital Electronics, Signals and Systems.



Mr. Neeraj Kumar is presently working as Assistant Professor in Electronics and Communication Engineering Department at Chitkara University, Himachal Pradesh, India. He has more than 3 years of teaching experience. His area of interest is Wireless Communication, Signals and Systems.



Ms. Vartika Mehta is presently pursuing her M.Tech in Communication System at Graphic Era Hill University, Dehradun, Uttarakhand, India. She has 1 year of Software Testing Experience. Her area of interest is Joomla, Opencart frame work, Executing test cases, Jmeter tools, Xampp server, Wireless Communication, Signals and Systems.